

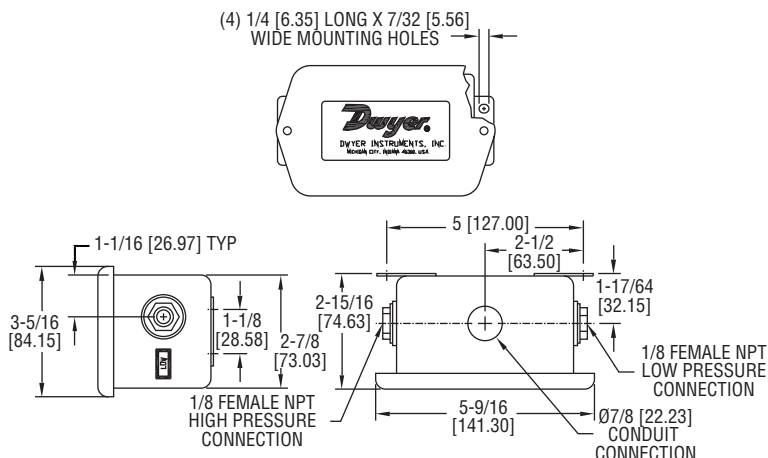

Series 647 Wet/Wet Differential Pressure Transmitter

Specifications - Installation and Operating Instructions



The Series 647 Wet/Wet Differential Pressure Transmitter is designed for use with compatible liquids or gases and can accurately measure differential pressure down to 1" H₂O. The transmitter contains a fast response piezoresistive sensor and a unique isolation system ideal for HVAC systems, filter monitoring, variable speed drive control, air/liquid flow monitoring and process control.

The Series 647 Wet/Wet Differential Pressure Transmitter features excellent repeatability, low hysteresis and accurate operation over a broad temperature range. Units have an adjustable zero and span and feature reverse polarity protection.

MECHANICAL INSTALLATION

NOTICE

The Series 647 Wet/Wet Differential Pressure Transmitter can be mounted in any position, however, be alert to moisture passing through a non-waterproof electrical connector.

The unit can measure gauge, vacuum or differential pressure. Follow the directions below for the appropriate port connections.

Gauge (Positive) pressure sensing: Connect media pressure port labeled "HIGH" with port labeled "LOW" vented to atmosphere.

Vacuum (Negative) pressure sensing: Connect media pressure to port labeled "LOW", with port labeled "HIGH" vented to atmosphere.

Differential pressure sensing: Connect the higher of the two media pressure to port labeled "HIGH", and the lower of the two pressures to port labeled "LOW".

SPECIFICATIONS

Service: Compatible gases or liquids on both pressure and reference sides.

Wetted Materials: Brass, vinyl, glass-filled polyester, silicon, and fluorosilicone.

Accuracy: ±1.0% FS.

Stability: ±1.5% FS output/year.

Temperature Limits: 32 to 122°F (0 to 50°C).

Pressure Limits: Ranges 1 in w.c. to 5 psi: 20 psi, 15 psi range: 45 psi, 30 psi range: 60 psi.

Thermal Effects: Zero: ±0.05% FS/°F, Span: ±0.05% rdg/°F.

Power Requirements: 18 to 30 VDC.

Output Signal: 4 to 20 mA, 2-wire.

Zero and Span Adjustments: Adjustable, ±10%.

Loop Resistance: 400Ω @ 18 VDC, 600Ω @ 24 VDC, 1000Ω @ 30 VDC.

Electrical Connection: Screw terminals, reverse polarity protected.

Process Connections: Two 1/8" female NPT.

Housing: Gasketed steel epoxy painted, NEMA 4 (IP56).

Weight: 14 oz (397 g).

Model	Range	Model	Range
647-0	0 to 1" w.c.	647-5	0 to 1 psid
647-1	0 to 3" w.c.	647-6	0 to 5 psid
647-2	0 to 25" w.c.	647-7	0 to 15 psid
647-3	0 to 5" w.c.	647-8	0 to 30 psid
647-4	0 to 10" w.c.		

The Series 647 Wet/Wet Differential Pressure Transmitters have 1/8" female NPT port connectors. ALWAYS USE A SECOND WRENCH TO HOLD THE PORT HEX NUT, THEREBY ELIMINATING THE POSSIBILITY OF ROTATING THE BRASS PORT FITTING. Use thread sealant or teflon tape to insure proper sealing.

ELECTRICAL CONNECTIONS

Make all wiring connections with the power off. All circuits must be wired to the National Electrical Code, Class 1, and in conformance with all applicable codes and requirements with approved wiring practices. See Figure 1 below for appropriate wiring connections

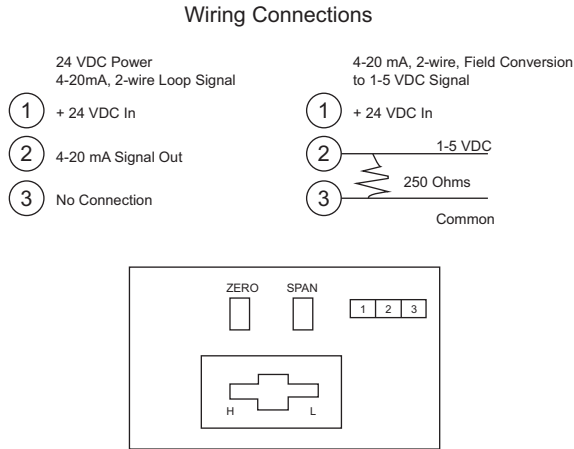

Figure 1

OPERATION

After applying power, allow approximately 20 to 30 minutes for stabilization of signal.

When operating at low differential pressures of less than 5" w.c. or in applications where the pressure is fluctuating rapidly – it is advisable to insert "snubbers" for air flow restrictors in the input lines. This serves to "steady" the output signal and keeps the signal from bouncing erratically.

ADJUSTMENTS

The Series 647 transmitters are adjusted for the specified range at the factory and should not require further adjustments. If necessary or desirable, the zero and span may be adjusted, however, the requested full scale range as shipped is established with fixed resistors minimizing the range of adjustment. The average full scale adjustment is $\pm 10\%$ for the range shipped.

"Z" – Zero Control is adjusted for 4 mA output signal at 0 psi or minimum pressure.

"S" – Span Control is adjusted to change the full scale range of the transmitter.

Due to resistor values required to compensate for the null off-set of the sensing module, evidence of Zero and Span interaction may be experienced in readjusting.

Do not adjust the bridge balance and temperature compensation controls.

WARNING Fluid hammer and surges can destroy any pressure transducer and must always be avoided. A pressure snubber should be installed to eliminate the damaging hammer effects.

Fluid hammer occurs when a liquid flow is suddenly stopped, as with quick closing solenoid valves. Surges occur when flow is suddenly begun, as when a pump is turned on at full power or a valve is opened quickly.

MAINTENANCE

After final installation of the Series 647 Wet/Wet Differential Pressure Transmitter, no routine maintenance is required. Periodic checks of connections is recommended. Please contact Dwyer Instruments, Inc. before returning unit for repair to review information relative to your application. When returning a product to the factory, carefully package and ship freight prepaid. Be sure to include a complete description of the application and problem and identify any hazardous material used with the product.